

**An Ideal Power Buffer** The supercapacitor's high energy storage and high power delivery make it ideal to buffer a high power load from a low power energy harvesting source, as shown in Fig 1.

The source sees the average load, which with appropriate interface electronics, will be a low power constant load set at the maximum power point. The load sees a low impedance source that can deliver the power needed for the duration of

the high power event. Consider a sensor that transmits data at 100mW for 1 second once an hour. If an HS230 is charged to 3.3V just prior to the transmission, then during the transmission it will only discharge to 3.27V. The average power is  $0.1W/3600 = 28\mu W$ . If the circuit is 60% efficient, then the source only needs to deliver  $< 50\mu W$  to re-charge the supercapacitor between transmissions. In Fig 1, the supercapacitor is placed after the Interface Electronics, so the Interface Electronics can be sized for the average power of  $50\mu W$  rather than the peak power of 100mW. A discharged supercapacitor will look like a short circuit to the source, so the interface electronics must manage the inrush current when the source is first connected to a supercapacitor at 0V.

Read more at: <http://www.energyharvestingjournal.com/articles/using-a-supercapacitor-to-manage-your-power-00001921.asp?sessionId=1>

As explained above, supercapacitors are low voltage devices and several need to be strung in series to achieve a practical working voltage. In most

cases, two organic electrolyte cells in series achieve the desired voltage, typically one of 5V, 4.2V, 3.6V or 3.3V. However, different cells will have slightly different leakage currents, with different VSCAP vs ILEAKAGE characteristics, but since they are in series, without any balancing circuit, they must have the same current flowing through them. In this case, the cells will re-distribute charge between themselves, i.e. adjust their voltage, to so their leakage currents will be equal. This leaves one of the cells is in danger of going over voltage. The simplest balancing circuit is a pair of resistors, one across each cell, in the range of 1KΩ - 39KΩ, depending on the operating temperature & voltage. However, this solution will draw too much current for most energy harvesting applications. The solution that draws minimal current is an active balance circuit using an ultra low current rail-rail op amp. The circuit in Fig 5 is an example of this and draws only 2 - 3μA, including supercapacitor leakage current, once the supercapacitor has reached equilibrium leakage current.

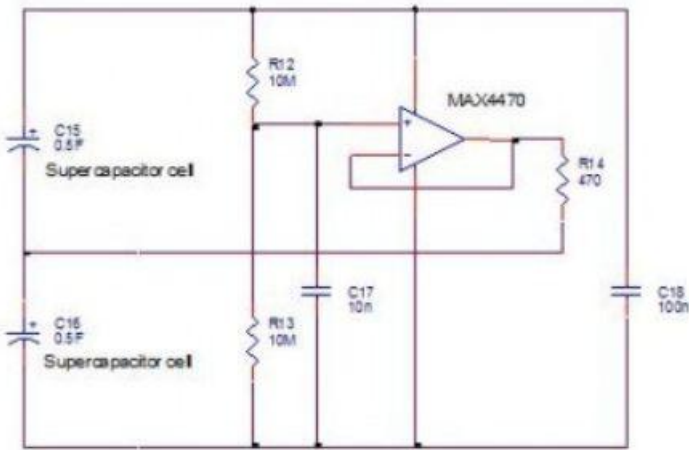

Fig 5: Lowcurrent active balance circuit



Above is photo of supercap wired to solar cell. Basic design.

7. After 5 seconds (sec.) in the sunlight with the motor spinning, stop the timer and block the sunlight from hitting the solar cell with a piece of cardboard. The motor should spin for a few seconds while in the shade, until it has drained the energy from the supercapacitor. b. The time until the motor stops spinning after it has been moved to the shade is the time it takes for the supercapacitor to discharge.

### Ultracapacitor Voltage Limiting Circuit

Supercapacitors are working their way into more and more applications where electrical energy needs to be stored. These robust devices can be charged and discharged 1000s of times and will typically outlast a battery. Many supercap manufacturers claim a life span of 10 years or more. A supercapacitor is often chosen to supply power to low current load for many hours at a time, recharged by a solar panel.

If supercapacitors have a maximum voltage rating. When charging these devices, that voltage should not be exceeded. Doing so can damage the device. In many applications several capacitors are wired in series, to produce a capacitor bank with a higher voltage. But even if the proper charging voltage is used the weakest device in the string will charge up first.



Without a circuit to limit the voltage across each part, the weakest part in the series string will be overcharged as the rest of the parts in the string finish their charge. The circuit below solves this over-voltage problem by balancing the string with a voltage limiting circuit across each capacitor.

The circuit diverts charging current around each part, when the voltage reaches a critical point. The circuit is really a classic 2.65v shunt type voltage regulator. It takes advantage of a LMP2231 low voltage op amp from National Semiconductor, a low current LM385 voltage reference, also from National, and a PMV30UN n-channel FET from NXP Semiconductors, which has a low gate-source threshold voltage.

In the application shown, three 310 farad supercapacitors from Maxwell, part number BCAP0310, are wired in series, to form an energy storage bank. The voltage from the bank is connected to a Seiko low voltage drop 3v voltage regulator. Power to charge the supercapacitor bank comes from a 3 watt 9v solar panel, with a short circuit current of about 300ma. The three voltage limiting circuits keep the voltage across each capacitor at 2.65v for a total of 7.95v for the capacitor bank, when fully charged.

A solar panel will typically produce about 5% of full power when the sky is heavily overcast. That means that a minimum of 15ma could be expected from the solar panel during about 8 hours of daylight. If the 3v DC output is restricted to an average of 5ma of current, then there would be enough charge in the capacitor for about 24 hours of complete darkness. Up to 100ma of peak current could be drawn from the 3v supply if needed for such applications as a RF transmitter. Energy drawn from the capacitor bank during night operation is restored by the solar panel.

*Click on Drawing Below to view PDF version of Schematic*

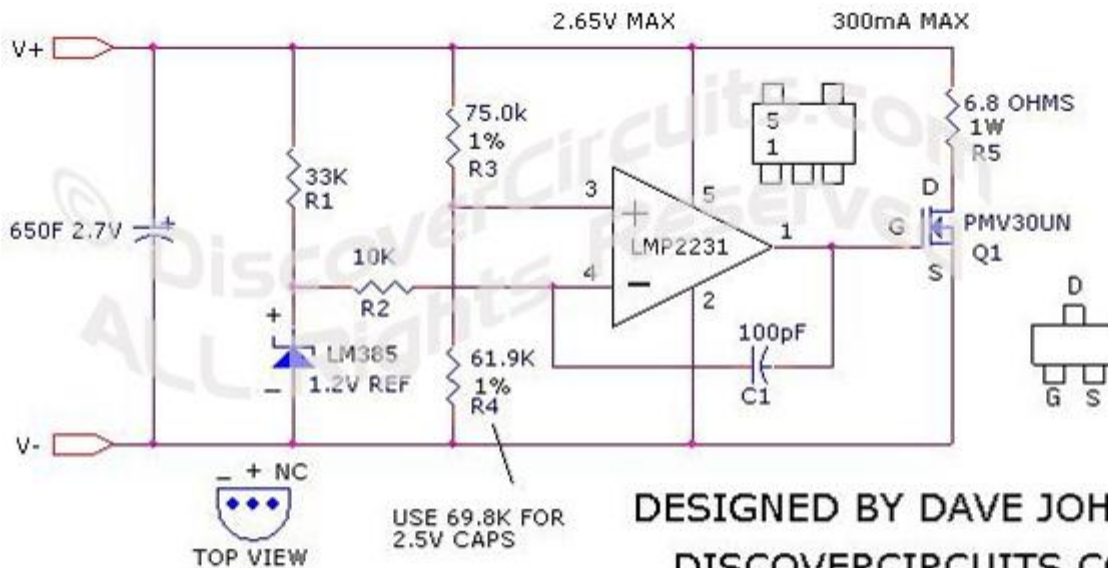

DESIGNED BY DAVE JOHNSON  
 DISCOVERCIRCUITS.COM  
 ALL RIGHTS RESERVED

DRAWN BY: DAVE JOHNSON

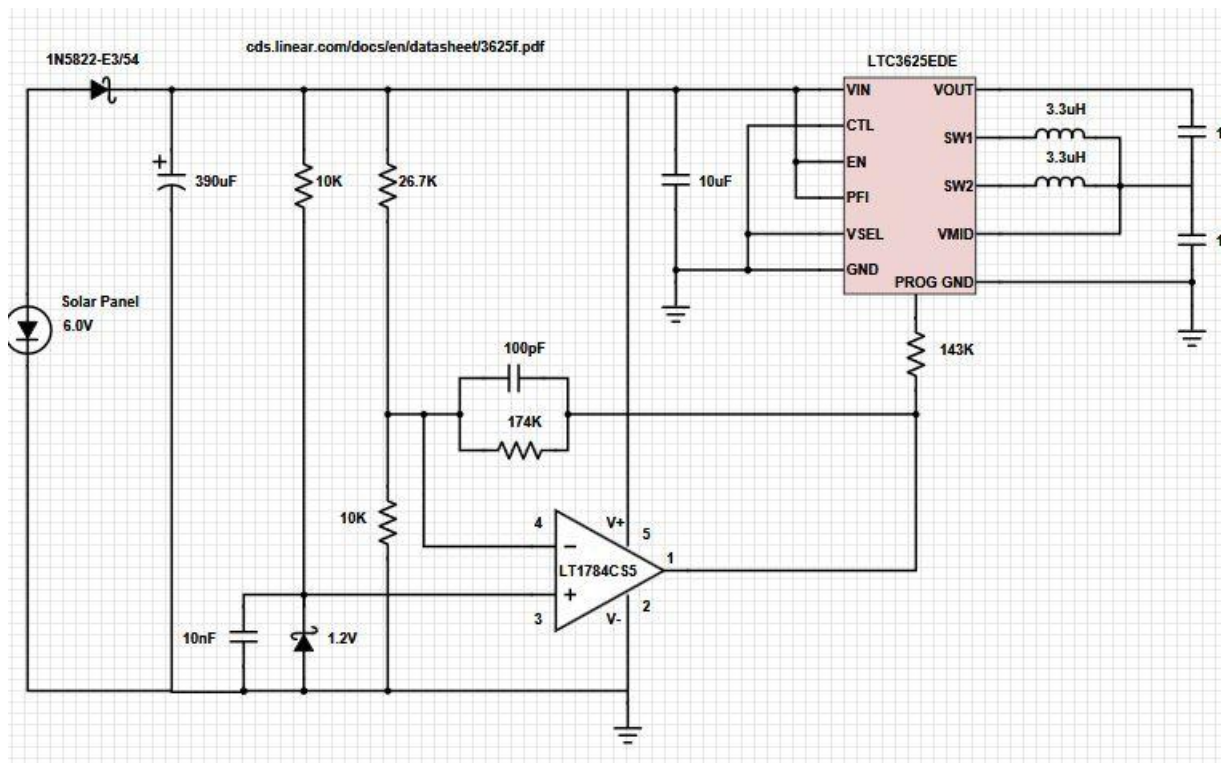

Solar panel super cap diagram

### Solar Power Voltage Boosters

ZSPM4523 – EXCELLENT CHOICE  
 1.5A Solar Charger Regulator for Super Capacitors  
<http://www.zmdi.com/zspm4523>

Voltage Booster for Solar Panel using Super-Cap:

As for the hardware side, it's using a NCP1402 voltage booster circuit to boost the voltage up to the required 3.3v for a white LED. The NCP1402 is perfect for this application as it will self-start at just 0.9v and will then produce light via the LED all the way down to 0.2v. This allows us to use the full capacity of the supercapacitor instead of cutting off the power at 0.9v with a chemical battery.

2.5 volt supercaps perform best when the voltage range is between 1.5 and 2.5 volts

1.3 to 3ma is the amperage on cordless screwdrivers.

This company sells devices that sap the entire energy out of a battery or supercapacitor completely, much like a joule thief. It also boosts up the voltage level for low power.

I've been experimenting with the 2.5v 2600F Maxwell caps by putting six in series to make a 15V max. pack & putting those packs in parallel & running them from 14V down to 11V with a 1500 watt inverter connected to them. I've been able to run a small microwave for about 3 or 4 minutes and a small beer fridge for 9 minutes, a 9 watt led bulb for about 40 minutes, etc. I dont have any balancing circuitry on them & wouldn't think it would be necessary since I'm not charging the packs past 14 volts. Was even thinking about adding a seventh cap into the series strings so they could go up to 17.5V without damage to act as balancing protection without zenner diodes. I've got 24 caps in this setup so far & would like to parallel some more packs in line but aren't sure if I'm headed for disaster by having too many in parallel. If I keep going for longer run times by paralleling more I'm wondering if the amps will reach a critical level??? So far no problems but I'm scared to go too much farther at this point until I meet a mathematical genius. I'm trying to make this a solar generator

And I found that by far the fastest way to charge these capacitors is with a solar panel. And with a solar panel, you don't have to worry about frying your power supply, or worry about using a big resistor. I haven't done a charge time using the panel, but I did used to charge them up with my electric scooter's charger, or by hooking them up to some 12V batteries,(with a 40 watt light bulb as a resistor) and it took hours that way. As apposed to maybe an hour of good sunshine on a solar panel. I make my solar panels, so I used a few spare cells and some tape to make a small 2.5V 3 amp solar panel, which worked great when I only had one cap. Now I have a full sized panel with a wire on it for 18V output and 13V output that I use.(I like having the option of running 12V appliances without a battery)

Also, when I used a blocking diode, the charging amperage went down sharply, and the voltage dropped as well. By not using a diode between the capacitors and solar panel, you get a HUGE difference in charge time.

So use a solar panel that doesn't exceed the maximum voltage of the capacitors, no blocking diode, and just disconnect it when the sun goes down.

And if you watched the scooter video, that's about as far as I got, because the voltage dropped too low and the controller thought the batteries were dead. I'm looking into getting a DC/DC converter to step up the 12V bank to 24V so I can use more of the stored power. I'm thinking I should get almost a mile after that? But at half speed and with a solar panel in tow, there's no telling how far I could go without actually testing it. I'll have to do that sometime this summer.

And I'm scared to charge them with bedini's or anything else with voltage spikes, because these caps use a water based electrolyte, so I'm scared of electrolysis occurring and Hydrogen gas accumulation. I know I overcharged one of them one time to over 3 volts, and it was burning hot. And I don't know if the hydrogen can turn back into water inside of the cap without some activation energy(a spark) to make it recombine with the oxygen inside.

This powerful step-up/step-down regulator efficiently produces a fixed 12 V output from input voltages between 3 V and 30 V while allowing a typical output current of up to 2 A when the input voltage is close to the output voltage and offering typical efficiencies of 80% to 90%. Its ability to convert both higher and lower input voltages makes it useful for applications where the power supply voltage can vary greatly, as with batteries that start above but discharge below the regulated voltage.

<http://www.pololu.com/product/2574>

Solar Panel running wireless coil to charge motor  
<https://www.youtube.com/watch?v=LSeWQLO6S5A>

Instead of using a rechargeable battery supply with charger circuit, i have decided to use a 35F, 2.7V super capacitor to smooth and store power.

The power scheme will run along these lines:

Panel Array\* ==> Diode ==> Super Cap ==> Voltage boost to 5V via pololu voltage boost ==> Remainder of circuit

\*The output voltage will preferably be ~1.5V, as my super cap is rated at 2.7V and i hear a general rule of thumb is to keep the impressed voltage at around half the rating for long capacitor life.

I have several questions concerning this setup:

How can I ensure that the total power output by the panel(s) and capacitor will not cause the voltage boost (and subsequently my logic circuit) to "hiccup." That is

"The power supply will shutdown, then restart itself. This will repeat until either the overload (?) goes away, or a component in the power supply fails from trying."

Charging a supercapacitor with renewable energy is very easy, but there are some important steps to follow. Supercapacitors are polarized, which means that they have positive and negative terminals. Because of this, you have to properly connect your electricity source (wind turbine, solar cell, etc.) to the supercapacitor. Sometimes the terminals are marked with (+) and (-) signs, but you can always be sure that the longer lead from the supercapacitor is the positive terminal.

To determine the proper polarity of your turbine or solar cell, you will need to connect it to a multimeter. Make sure the wires from the multimeter are correctly installed as shown in the picture (black wire goes in COM port). If your voltage reading is positive, the lead connected to the red multimeter wire comes from the positive terminal. If the voltage reading is negative, the lead connected to the red multimeter wire comes from the negative terminal. It is a good idea to mark your wires with tape so you know which is positive and which is negative.

The positive lead from your wind turbine, solar cell, or battery should be attached to the long (+) lead on the supercapacitor. The negative lead corresponds to the short (-) lead on the supercapacitor. If you are sure you have the correct polarity, you can start to pump some energy into the supercapacitor! Turn the fan on to start your turbine or shine some light on your solar panel. Then wait about 1 1/2—2 minutes. After this time the supercapacitor should be charged up pretty well. Now you can use this stored energy to power small electrical gadgets!

**Experiments and Activities with Supercapacitors** Although these are relatively small supercapacitors with low overall power, they can still do a good amount of work after you charge them up! With the supercapacitor charged up, it will start powering devices as soon as you complete a circuit. Remember that LED and incandescent bulbs are also polarized, so you might have to switch the leads before you can get them to light up. You can also put a switch into your circuit. This will allow you to turn your electrical devices on and off by connecting and disconnecting the circuit. You should connect the supercapacitor, switch, and electrical device in series as shown in the picture.  
**What Can Kidwind Super-**

**Other Experiments:**

- **Wind Turbine Blade testing:** Set a time limit (try 2 minutes), and charge a supercapacitor using one set of blades. Then discharge the capacitor with some kind of load—pump water, run a propeller, or light a bulb. Time how long the charge lasts. The longer you run devices with the capacitor, the more power you have produced with your wind turbine. Then try another set of blades, keeping all other variables constant. Which blades were better?
- **Connect Multiple Supercapacitors:** What happens when you power a device using the power of more than one capacitor? Remember—always connect leads positive to negative. Can you pump more water? Light more bulbs?
- **Series vs. Parallel:** Try connecting the supercapacitor in a parallel circuit instead of in series. Does this change the output? This gets more interesting if you are using multiple supercapacitors.

**Supercapacitors and Solar Boats:** It is a really cool idea to connect a supercapacitor to your solar boat setup. That way, if the sun goes behind the cloud for a minute or two, you can use the stored energy from the supercapacitor to keep your boat zooming along until the sun shines again! Just connect the supercapacitor in series between the solar panel and the electric motor on your boat (make sure you've connected the right leads). When the panel activates in the sun, part of the electricity created will trickle into the supercapacitor, and part will go straight to your electric motor. You may find that the motor does not spin quite as fast while the supercapacitor is charging up. Though it might slow you down at first, this could really pay off later if the sun hides!

Supercapacitors are an essential energy storage mechanism in self-powered systems. Their high-energy capacities combined with their ability to provide high-power output make them ideal for ultra-low power wireless sensor node systems. Supercapacitors, however, discharge significantly during periods of low-energy harvesting input.

Energy harvesting ICs used to charge supercapacitors suffer from low efficiency during the initial charging stages until the supercapacitor reaches a nominal voltage. This causes a long wait for the supercapacitor to charge up to usable levels each time the system comes back up from a deep-sleep state, significantly hindering the widespread adoption of supercapacitors. This article describes ways to speed-up charging of a supercapacitor by more than 20 times when compared to existing systems. The solutions presented in this article use a solar cell as the energy harvester. These solutions are equally applicable to other energy harvesting sources as well.

These solutions are equally applicable to other energy harvesting sources as well.

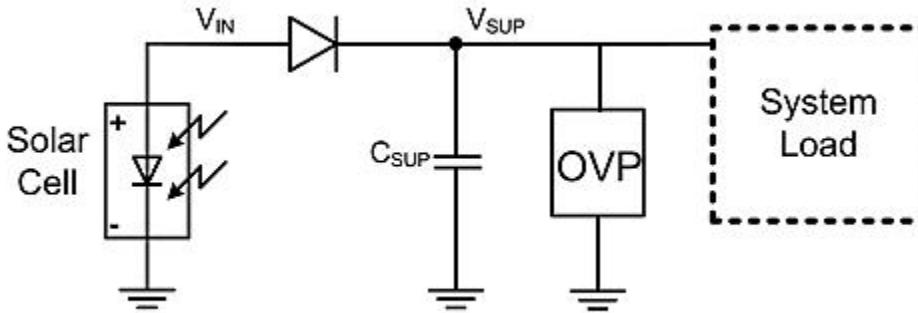

Figure 1. Schematic for charging a supercapacitor using a diode



Moulds (shot glass)

The way it works is very simple:

Supercapacitor gets charged with solar, by connecting two parts together and placing this in sun (see picture)  
When charged capacitor is connected to LED lamp the light is produced ( does fade with time, more farads more time it stays lit)

Part list:

4.8V 50mA PowerFilm solar cell (you can use any make, the one with larger current would charge capacitor quicker)  
1 Diode  
3V Supercapacitor 20F or more  
2.9-3V LED module  
2 X 2.1mm X 5.5mm DC socket female and 1 male connector

For finishings:

Sugru  
Fin clear film sheet  
Small glass jar with screw on lid

Take small piece of protective film of the metal strips at the sides, use your DC meter to determine the positive and negative side (cathode, anode) Solder diode to + and some wire to -, then solder other end of diode to + on dc socket and negative to -, I find it easier to stick the wire through the hole then solder.

The reason for using diode is to make sure that electricity flows in one direction.

For finishing, cut solar cell shape out of clear film, cut hole for dc socket, fit the panel in and apply sugru on sides, this step is quite tricky. The reason for using film is to give it more protection as these modules are not waterproofed and not UV balanced.

Connect led module to female dc socket by soldering, same as usual + to +, - to -. I used piece of diode wire it is nice and sturdy and only need short one, so its perfect.

Take the lid of a jar and make hole in the middle, stick the socket through and screw on the nut and washer (comes with socket).

You can go one step further and make it more safe and pretty by making colourful lid and rubber sleeve. To make sleeve wrap double layer of cling film around jar, and then form sugru around it, when set remove, if it not coming off, gently run the knife in between the jar and set sugru to loosen. This not only protects the jar from braking while travelling, but also works well as a stand for capsule shaped capacitor enclosure. For the lid, you can make permanent one by sticking sugru on it or removable, like me, using clingfilm, this option give you another option, whether to use this as lid or as part of lamp when its lit, my option again is second, so for this you would need to make hole for connector by cutting it out with knife (can do this when set)



For this I used solderless connector, so if you have the same one, just trim the wires a bit, bend top so it grips better, insert the positive wire (longer one) to + of connector and negative (arrow pointing down) to minus, I used round piece of black foam and place it in between the capacitor and connector, by poking holes in foam then sticking wires through, this makes it more sturdy and other benefits (sorry forgot to take picture of this)

---

## Here's how supercapacitors—double-layered capacitors with the ability to store far more energy than a traditional capacitor—can be used in conjunction with a small solar cell to power a wireless sensor node.

Wireless sensor networks (WSNs) are becoming more common. They solve problems in many applications, some of which can harvest solar energy to use as a limitless, battery-free energy source. In these applications a supercapacitor provides both temporary energy storage and power delivery. Harvested solar energy can power motion sensors to turn off lights if nobody is detected in a room, to dim lights depending on the light level in a room, to sense and report temperature for air conditioning or heating, and to monitor the security of remote locations while avoiding the need to replace and dispose of batteries.

However, small solar cells are very low power, delivering milliwatts of energy. So the problem becomes how to power wireless transmission, which requires higher amounts of power, using a low-power source.

### What Are Supercapacitors?

Supercapacitors are electrical double-layer capacitors. Their electrodes are made of porous carbon and have surface areas  $>1000 \text{ m}^2/\text{g}$ , providing a huge charge storage area. The electrodes are kept apart by a porous separator that allows ions in solution in the electrolyte to pass through, providing charge transport. The ions rest at the surface of the carbon electrode, so charge separation distance is on the order of nanometers. The size of the charge storage area, coupled with the nanoscale charge separation distance, provides the 'super' capacitance. Key parameters are capacitance (C), Equivalent Series Resistance (ESR), voltage, and volume or weight. Because supercapacitors contain no dielectric, the maximum voltage is determined by the breakdown voltage of the electrolyte. The highest maximum voltage available today is 2.7 V. Supercapacitors are connected in series to achieve higher voltages and a voltage balancing circuit is required to ensure that no individual cell goes overvoltage.

CAP-XX supercapacitors benefit from a nanotechnology construction that packs the highest energy and power densities into thin, prismatic packages that fit space-constrained devices. They store charge on nanoporous carbon electrodes on aluminum foil, arranged in multiple layers, and connected in parallel to minimize the resistance and maximize the capacitance of the device.

### Supercapacitors as a Power Buffer

Before there were low-impedance supercapacitors, designers had to size the entire power supply system for the load's peak power. For example, assume a sensor in a remote location is reporting its status once an hour by sensing an SMS that takes 3 s to transmit over a GPRS cellular network. The peak output power during transmission is  $\sim 7 \text{ W}$ . The average power during the transmission =  $7/8 \text{ W}$  for 3 s or  $\sim 2.6 \text{ J}$ . If a capacitor is placed at the input of a buck-boost regulator to allow a wider voltage window—with a maximum voltage of 5 V and minimum voltage of 2.5 V—then input peak power will be  $\sim 7 \text{ W}/85\%$  efficiency or  $\sim 8.3 \text{ W}$ , and the energy drawn will be  $\sim 3 \text{ J}$ . To meet these requirements you would require 0.4 F with ESR  $< 50 \text{ m}\Omega$ , or a supercapacitor. The alternative is to trickle-charge a battery that can deliver this power, possibly with the support of a tantalum or electrolytic capacitor for the 0.577 ms transmission peaks.

The supercapacitor's high energy storage and high power delivery (for CAP-XX supercapacitors these ranges are from 0.5–2 Wh/L and 50–100 kW/L, respectively) allow it to buffer a high-power load from a low-power energy-harvesting source, as shown in Figure 1. The source sees the average load, which with appropriate interface electronics, will be a low-power constant load set at the maximum power point. The load sees a low-impedance source that can deliver the power needed for the duration of the high-power event.

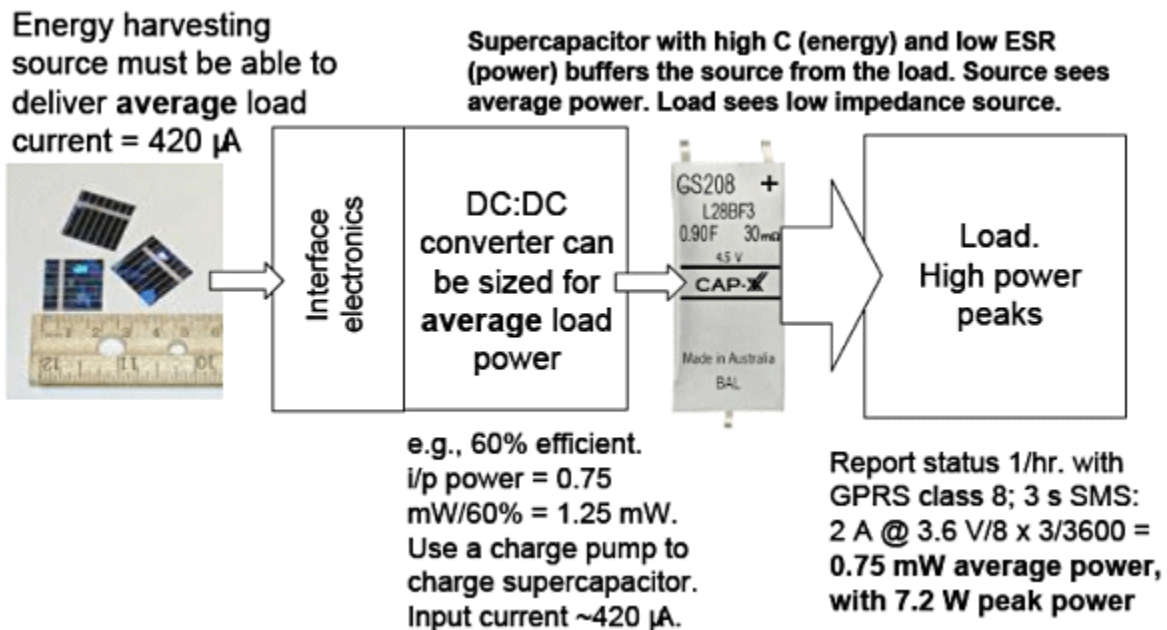

Figure 1. Using a supercapacitor as a power buffer

In our example, the average load power is 0.75 mW. A low-power solar cell needs to supply a little more than this power level (to overcome losses) to charge the supercapacitor, which then provides the GPRS module with the power required to send the SMS.

The supercapacitor is placed after the interface electronics, allowing designers to size the interface electronics and DC/DC converter for the average power of 1.25 mW rather than the peak power of 7 W. A discharged supercapacitor will look like a short circuit to the source, so the interface electronics must manage the inrush current when the source is first connected to a supercapacitor at 0 V.

#### Interfacing a Solar Cell to a Supercapacitor

There are four key principles to follow for any circuit that charges a supercapacitor from a solar cell. The circuit should:

- Start charging from 0 V
- Provide overvoltage protection for the supercapacitor
- Prevent the supercapacitor from discharging back into the solar cell when light levels drop
- Be designed for maximum efficiency

Figure 2 shows the equivalent circuit of a solar cell. The solar cell generates a current,  $I_{PH}$ , that is proportional to the light falling on the cell; if no load is connected then all the current flows through a diode (D), whose forward voltage is  $V_{OC}$ .  $R_P$  represents the leakage current and  $R_S$  represents connection losses, which are usually not significant. This behavior can be characterized by V- I curves that are provided with the solar cell datasheet. It is useful to characterize the solar cell yourself in the typical light conditions for your application. This can be done by connecting a 10  $\Omega$  current sense resistor and a potentiometer across the solar cell, from which you can measure load current and load voltage. The example shown in Figure 3, where the IXYS X0B17 solar cell has been characterized at various light levels, is an array of 3 cells in series.

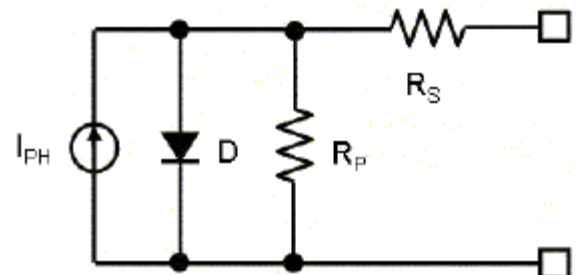

Figure 2. Simplified circuit model of a solar cell

- $V_{OC}$  of the solar cell at the maximum light levels for the application will be <2.75 V, which will equal the maximum voltage of the single-cell supercapacitor used. This means that the supercapacitor will not require over-voltage protection. Figure 3 confirms this is for the XOB17 solar cell.
- The load can operate at low voltages e.g., the load could be a boost converter with a minimum input voltage of 0.7 V or less (e.g., TPS61200 or MAX1763).
- Diode D1 prevents a charged supercapacitor from discharging back into the solar cell though diode D of the equivalent circuit shown in Figure 2. D1 should be chosen for low reverse leakage current and to minimize the forward voltage drop.
- The supercapacitor should be chosen to deliver the peak-power needs. This constrains the maximum ESR and, because the supercapacitor must support the peak load for its duration, constrains the minimum capacitance. In the circuit shown in Figure 4, we chose the CAP-XX HS130, 2.4 F, 26 m $\Omega$  ESR, supercapacitor.

## Uninterruptible power supply for short-time power back-up using ultracapacitors

**Abstract:** This paper presents an uninterruptible power supply capable of providing power for several seconds. Ultracapacitors are used as the storage method since they are suitable for pulse power applications and longer life time. Selection of ultracapacitors and controller design for associated power electronic converters are presented in this paper. Further simulation results of the proposed uninterruptible power supply are also included in the paper.

[edit] Ultracapacitors: why, how, and where is the technology

**Abstract:** This paper covers all the basics of Ultra capacitors from why we need them, their advantages, their working and a detailed comparison of various features of Ultra capacitors with that of batteries. Various concerns like the cost issues and the manufacturing problems of the technologies involved are discussed. The present status and the future scope of the technology is also covered.

[edit] Effective charging method for ultracapacitors

**Abstract:** One of the advantages of ultracapacitors is its high power capability, which is applicable for high rate of charging and discharging operation like motor starting and regenerative braking of an electric vehicle. This paper presents a new charging method for ultracapacitors. Comparing with batteries, ultracapacitor can accept a wide range of charging current and can be fully charged within a few minutes. Common chargers for ultracapacitors are usually equipped with current transducers and closed loop circuitry for current control, which are expensive and complicated. The proposed circuit consists of a minimum number of components. It does not require any current transducer or dedicated voltage/current control circuitry. A simple open-loop control system is applicable for the whole charging stage. It is free of stability problem and protects itself from being overloaded by ultracapacitor with zero initial charge. This paper presents the design and operation of the hardware circuit. Both simulation and experimental results are included.

[edit] Use of Super-Capacitor to Enhance Charging Performance of Stand-Alone Solar PV System

**Abstract:** The battery charging performance in a stand-alone solar PV system affects the PV system efficiency and the load operating time. The New Energy Center of National Taiwan University has been devoted to the development of a PWM charging technique to continue charging the lead-acid battery after the overcharge point to increase the battery storage capacity by more than 10%. The present study intends to use the super-capacitor to further increase the charge capacity before the overcharge point of the battery. The super-capacitor is connected in parallel to the lead-acid battery. This will reduce the overall charging impedance during the charge and increase the charging current, especially in sunny weather. A system dynamics model of the lead-acid battery and super-capacitor was derived and the control system simulation was carried out to predict the charging performance for various weathers. It shows that the overall battery impedance decreases and charging power increases with increasing solar radiation. An outdoor comparative test for two identical PV systems with and without supercapacitor was carried out. The use of super-capacitor is shown to be able to increase the lead-acid charging capacity by more than 25% at sunny weather and 10% in cloudy weather.

[edit] Maximum power transfer tracking for a photovoltaic-supercapacitor energy system

**Abstract:** It is important to maintain high efficiency when charging electrical energy storage elements so as to achieve holistic optimization from an energy generation source (e.g., a solar cell array) to an energy storage element (e.g., a supercapacitor bank). Previous maximum power point tracking (MPPT) methods do not consider the fact that efficiency of the charger varies depending on the power output level of the energy generation source and the state of charge of the storage element. This paper is the first paper to optimize the efficiency of a supercapacitor charging process by utilizing the MPPT technique and simultaneously considering the variable charger efficiency. More precisely, previous MPPT methods only maximize the power output of the energy generation source, but they do not guarantee the maximum energy is stored in the energy storage element. Note that the load device takes its energy from the storage element so it is important to maximize energy transfer from the source into the storage element. We present a rigorous framework to determine the optimal capacitance of a supercapacitor and optimal configuration of a solar cell array so as to maximize the efficiency of energy transfer from the solar cells into a bank of supercapacitors. Experimental results show the efficacy of the proposed technique and design optimization framework.

[edit] A novel charging control scheme for super capacitor energy storage in photovoltaic generation system

**Abstract:** A control scheme is described to charge series-connected super capacitors for photovoltaic generation systems. Based on the features of the super capacitors charge, the control scheme consists of three modes, i.e., the constant current charge mode, the constant power charge mode, and the constant voltage charge mode. The shift of three modes can be realized by controlling the duty of IGBT in the Boost-Buck converter system. Meanwhile, the high voltage, which is more suitable for application, can be obtained. Compared with the normal charge method with series-connected current-limiting resistance and the charge method with the constant current charge mode and the constant voltage charge mode, the proposed charging control scheme can shorten the charging time and improve the usage of the electric power generated from the PV arrays. The advantage described above is verified by simulations.

[edit] Research on Supercapacitor Charging Efficiency of Photovoltaic System

**Abstract:** The model of supercapacitor and its charging performance with constant voltage charging mode, constant current charging mode and constant power charging mode were studied. A numerical method to calculate the efficiency of these charging modes was inducted. To analyze the storage performance of supercapacitor in PV system, using this method, the maximum charging efficiencies of supercapacitor when its terminal voltage raise from zero to the rated voltage with different charging modes were presented. The multi-stage charging efficiency curves were retrieved, which indicated that the constant power charging mode is more suitable when supercapacitor are charged in PV system. A MPPT plus constant power control charging strategy using two-stage Buck-Boost converter to charge supercapacitor in PV system was proposed. The simulation results showed that this strategy effectively ensure the charging efficiency of the system.

[edit] Technology Research Of Novel Energy Storage Control For The PV Generation System

**Abstract:** Recent years, technologies for new energy have developed rapidly since the energy crisis and the environmental pollution got worse. And the solar energy generation technology tends towards the stage of a large number of applications in engineering from the research stage. This paper designed a grid-connected PV system firstly, then introduced the operation principle of the various parts as well with the control strategy of the power flow. The design of energy storage is of great significance as the output power of PV cells array is greatly affected by the light intensity



and the temperature change. Battery is used as the energy storage device normally in the traditional energy storage system. In this paper, it used the Ultracapacitor as the energy storage device after comparing with the battery, and designed the charge-discharge control strategy according to the characteristics of the ultracapacitor. Finally it verified the feasibility of the energy storage control strategy through the simulation models which was built based on the PSCAD/EMTDC platform.

[edit] Using Ultracapacitors in Photovoltaic Systems. A technical proposal

[edit] Control of Bidirectional DC-DC Converter for Supercapacitor Automotive Application

Abstract: The purpose of this paper is to study a sliding- mode controller to regulate the voltage and current a bidirectional DC-DC converter . The converter is placed between a supercapacitor array (SA) and a DC-link fixed at 42V. Supercapacitor array is regarded as powered system with high current and low voltage source. The DC-DC converter is bidirectional: it is a Boost converter when the SA provides the power requirement of the DC link and a Buck converter when SA is charged from the DC link. The output voltage ( Boost case) and the inductor current (Buck case) are regulated at constant values using a sliding mode approach.

[edit] MCU Controlled DC-DC Buck/Boost Converter for Supercapacitors

Abstract: This work is focused on DC to DC conversion, what is a crucial function to enable the use of supercapacitors for energy storage. A theoretical study and comparison of methods, algorithms and techniques for software controlled DC-DC converters have been used to develop a system what can step up or down a DC variable voltage and transform it into a steady state voltage. As a result a new control theory based on Bang-Bang control has been developed with an ARM LPC1768 processor. It was implemented to solve the commercial converters problems because they cannot work with supercapacitors due to their low internal resistance. The outcome is a device what can provide a programmable voltage between 4.5 V and 25 V, hardware can support up to 6 A and it is able to control the operating current owing through the converter. It can be used with the supercapacitors as shown in this work but it can also be used as a general platform for voltage and energy conversion. Furthermore, the designed hardware has the potential to work with smart grids via Ethernet connector, solar panels with MPPT algorithms and, at last, manage energy between different kinds of DC voltage sources and devices.

[edit] Isolated Bidirectional DC-DC Converter for SuperCapacitor Applications

Abstract: This paper proposes a new bidirectional DC/DC converter for supercapacitor applications. The proposed converter has a parallel structure in supercapacitor side (where voltage is low and current is high) and a series structure in the other side. This structure increases efficiency of the converter. For current sharing in the parallel side of the proposed converter, two different methods are recommended and compared in this paper: Current balancing transformer (CBT) and two separate inductors (TSI). Simulation and experimental results show performance of the proposed converter.

[edit] MODELING BATTERY-ULTRACAPACITOR HYBRID SYSTEMS FOR SOLAR AND WIND APPLICATIONS

Abstract: The purpose of this study was to quantify the improvement in the performance of a battery with the addition of an ultracapacitor as an auxiliary energy storage device for solar and wind applications. The improvement in performance was demonstrated through simulation and modeling. A ceramic battery model and a third order ultracapacitor ladder model were implemented in Matlab/Simulink. Sample battery load cycles for solar and wind applications have been obtained from literature and the corresponding C-rates were quantified. The C-rate for the solar load cycle was found to be 0.3C and 0.2C for the wind load cycle. The performance of the battery- ultracapacitor system was checked for the sample solar and wind load cycles and compared with the performance of the battery system without an ultracapacitor. A reduction of 50.5% in battery RMS currents was found for the solar load cycle and 60.9% for the wind load cycle. This reduction in battery RMS currents was found to be directly proportional to the ultracapacitor contribution. Given the low C-rates for the sample load cycles it was deduced that the addition of an ultracapacitor will not significantly improve the battery life to justify the high initial costs.

[edit] Sizing Ultracapacitors For Hybrid Electric Vehicles

Abstract: An efficient energy storage medium is essential in all hybrid electric vehicles. The advances in double layer electrolytic capacitor technology have opened new areas to complement batteries as a storage medium. In this paper we will review some of the present applications of ultracapacitors as well as to provide guidelines for sizing ultracapacitors for minimal mass in hybrid electric vehicles. Equations for both constant current as well as constant power discharge are discussed. An iterative method for determining the minimum number of ultracapacitor cells is introduced. The effects of ultracapacitor sizing on the rating of interface power electronics are examined.

[edit] ULTRACAPACITOR/ BATTERY HYBRID FOR SOLAR ENERGY STORAGE

Abstract: All stand alone photovoltaic systems require an energy buffer to bridge the mismatch between available and required energy. Battery technology, chiefly the lead acid battery, is the most popular form of energy storage utilized. Nevertheless in a photovoltaic application, the storage battery generally has the highest life time cost in the system, it has a profound effect on the systems reliability and global performance. Photovoltaic panels are not an ideal source for charging batteries as the output is unreliable and heavily dependent on weather conditions an optimum charge/ discharge cycle cannot be guaranteed. Using an ultracapacitor and battery hybrid system it is aimed to prolong the lifetime of the battery, making the overall system more efficient and reliable. The ultracapacitor/ battery hybrid system will be controlled by an energy management system (EMS) implemented in Labview. The EMS will implement maximum power point tracking (MPPT) and the chosen battery charging algorithm.

[edit] Ultracapacitor Energy Storage for MicroGrid Micro-generation

Abstract: A microsource interface with energy storage would help to realise the plug and play functionality of a MicroGrid. This paper discusses the energy storage interface. Selection and sizing of the energy storage unit is explained. A bi-directional converter is used to interface the storage, and a controller is implemented to keep the output voltage of the converter approximately constant. The energy storage unit was connected to a PV system in simulation. The system response to the irradiance, temperature and load variations were analysed in this paper.

[edit] TurboCap: A Batteryless, Supercapacitor-based Power Supply for Mini-FDPM

**Abstract:** This paper describes TurboCap, a batteryless, supercapacitor-based power supply subsystem for a handheld, laser-based breast cancer detector named the Mini-FDPM. Supercapacitors have high power density and are a better match with the power usage pattern than batteries. However, the multivoltage requirement poses a new problem on the selection of supercapacitor topology for conversion efficiency and for formfactor minimization. Experimental results show that our design can efficiently power the Mini-FDPM system for energy-efficient, untethered operation in a compact size while supporting fast recharge.

[edit] Energy Harvesting by Sweeping Voltage-Escalated Charging of a Reconfigurable Supercapacitor Array

**Abstract:** EscaCap is an energy harvester that uses a boostup charge pump to perform maximum power-transfer tracking (MPTT) while charging a reservoir supercapacitor array (RSA) with a reconfigurable topology. Unlike buck-down type harvesters, the voltage-doubling charge pump of EscaCap enables the sensor nodes to operate under low ambient power conditions. The supercapacitors in the RSA can be dynamically configured for series or parallel topologies by means of a switch array for not only minimizing leakage of the supercapacitors but also improving the charging speed. Furthermore, the RSA of EscaCap is modular and can be easily expanded. Experimental results show that EscaCap can harvest energy efficiently under low and high solar irradiation conditions, achieve shorter charging time, and demonstrate flexibility and robustness.

[edit] Efficient Charging of Supercapacitors for Extended Lifetime of Wireless Sensor Nodes

**Abstract:** This paper describes an efficient charging method for a supercapacitor-operated, solar-powered wireless sensor node called Everlast. Unlike traditional wireless sensors that store energy in batteries, Everlast's use of supercapacitors enables the system to operate for an estimated lifetime of 20 years without any maintenance. The novelty of this system lies in the feed-forward, pulse frequency modulated converter and open-circuit solar voltage method for maximum power point tracking (MPPT), enabling the solar cell to efficiently charge the supercapacitor and power the node. Experimental results show that by its low-complexity MPPT, Everlast can achieve over 89% conversion efficiency with lower power overhead than the state-of-the-art by two orders of magnitude, while enabling charging a supercapacitor up to 400% faster than direct charging. This makes Everlast particularly applicable to miniature-scale, high-impedance energy harvesting systems.

[edit] A new simplified model of Double-Layer Capacitors

**Abstract:** The paper introduces a simplified model, named "two branches model", to characterize the electrical behaviour of the DLCs (Double Layer Capacitors). The new model is very similar to many others in literature from the circuit point of view, however the process of identification of its parameters is easier and faster. This new identification process can be followed in other some model proposed in literature. Experimental charge tests have been executed on supercapacitors of two different labels (Epcos and Maxwell) and size (between 100F to 600F). The experimental results and the performed simulations have been reported in order to verify the validity of the new identification proposed method.

[edit] Modeling and Simulation of Supercapacitors

**Abstract:** In this paper we present some models for supercapacitors. The supercapacitors are used more and more in high level industries such as: traction systems, automotive industry, aerospace industry, telecommunications etc. Understanding supercapacitors operation mode is necessary so we can be able to determine the applications which require these components, and to be able to choose between supercapacitors and other energy storage devices. In this paper were used some models for the implementation of supercapacitors, and the simulations made in Orcad 9.2 to determine their operation, are in time and frequency domain. Also, the models were implemented in Simulink 7.5 and the simulation results prove the models accuracy. Two test measurements on the ECOND Pscap350 supercapacitor were realized and using the measurement data, two methods to compute the parameters are presented.

[edit] High Power DC-to-DC Converter For Supercapacitors

**Abstract:** The purpose of this paper is to present Solectria's approach to the design and realization of a high power, nonisolated DC-to-DC converter for supercapacitors. The study focuses on supercapacitor specific design rules and on how to integrate the unit into a system with other energy storage devices and converters. Two applications are presented to illustrate the validity of the suggested approach: An electric vehicle with supercapacitor load leveling, and a 50 kW pulse power source.

[edit] Time domain validation of ultracapacitor fractional order model

**Abstract:** In this paper, the modeling of the ultracapacitor using fractional order model is shown. The derivation of time domain response of the ultracapacitor and system with the ultracapacitor is presented. The results of frequency domain identification were used to validate the response of the ultracapacitor in time domain. All theoretical results are compared with the response of the physical system with the ultracapacitor. Then the issue of capacity for the ultracapacitors is shown and discussed.

[edit] A physical based model of power electric double-layer supercapacitors

**Abstract:** Recent developments in the field of supercapacitors have led to the achievement of high specific energy and high specific power devices. Due to capacitances of several hundred farads and serial resistances of less than one milliohm, these new components are suitable for energy storage in high power electronic applications, especially in the field of management of embarked electrical power (hybrid power sources, energy recovery). This paper presents theory, characterisation and experimental validation of an accurate electric double-layer supercapacitor model based on the physics of phenomena governing charges storage, which theoretically leads to a transmission line with voltage dependant distributed capacitance.

[edit] PSiM Based Electric Modeling of Supercapacitors for Line Voltage Regulation of Electric Train System

**Abstract:** Supercapacitor can be used for energy storage and peak power control in order to increase the efficiency and the life cycle of the system. Recent developments in the field of supercapacitors have led to the achievement of high specific energy and high specific power devices. Due to the capacitances of several hundred farads and serial resistances of less than one milliohm, these new components are suitable for energy storage in high power electronic applications, especially in the field of management of embarked electrical power (hybrid power sources, energy recovery). This paper presents a method to identify the equivalent circuit parameters of supercapacitor by the experimental results. In order to validate this method, parameters of a Maxwell BCAP 3000F are extracted from the experiment and then the equivalent circuit model using parameters is implemented by using the PSiM software. Finally, experimental and simulation results are compared to verify the electric modeling of some supercapacitors.

### Solar Supercapacitor Power Supplies

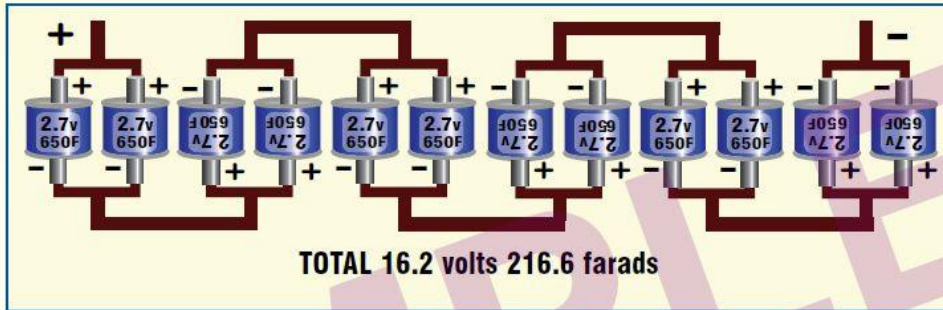

Parallel connected pairs of supercapacitors connected in series

For some applications this loss of capacitance is not of importance. However, for other applications, more capacitance may be required at these higher voltages. In that case you can use a parallel series arrangement which connects two or more cells in parallel and then connects these parallel connected capacitors to a similar parallel connected string in series. For example, if you connected twelve 650 farad, 2.7 volt supercapacitors in parallel-series as in the illustration, you would get 16.2 volts, at around 216.6 farad capacity.

You can, of course add more capacitors in your parallel string to augment capacity but it begins to get expensive. There are other less expensive ways to increase voltage using DC to DC converters with a parallel string.

### Solar Supercapacitor Power Supplies

Supercapacitors are presently available in two voltage ratings, 2.5, and 2.7 volts per cell. A bank of six series connected 2.5 volt supercapacitors will give you a total voltage of 15 volts. A bank of six series connected 2.7 volt supercapacitors will give you a total voltage of 16.2 volts. At first glance it would seem that you need to use the 2.7 volt bank at 16.2 volts to cover the 15.5 volts needed for the system. This would be a good choice; however, you can also use the 2.5 volt supercapacitors as they have a overcharge margin of about .1 per cell. This would allow you about 15.6 volts for charging. This is just within the range of general charging and equalization voltage needed.



Parallel connected 2.0 volt hybrid system



## Universal solar supercapacitor power supply

As an experimenter, I need a power supply that is flexible and portable. Sometimes I need AC and sometimes I need DC electricity. Sometimes I need high voltage, sometimes I need a specific low voltage. Sometimes I need the equipment in the laboratory and sometimes I need it in the field.

Of course everything has its limitations, but I have found that a dual 2.5 volt/15 volt solar supercapacitor supply with a few attachments is quite useful for a variety of situations and applications. The supply is simple in that it contains one parallel connected supercapacitor bank, and one series connected supercapacitor bank. The 15 volt bank is charged by a 12 volt system PV panel and the 2.5 volt bank is powered by a 2.5 volt system panel. The power supply can be used while connected to the panels, or disconnected from the panels when the supercapacitors are charged up.



I'm testing ZMDI's new (Feb '13) MPPT Supercapacitor Solar Charge Controller as an upgrade for the upcoming v3.0 Infinity Sun Jar. This chip has MPPT (Maximum Power Point Tracking) to help squeeze more power out of a solar cell to more efficiently charge a supercapacitor. I tested this against v2.0 Infinity Sun Jar's charging system which was nothing more than a solar cell coupled to a supercapacitor with a blocking diode to prevent reverse flow of power at night time. The results are the new chip is 400% more efficient than the traditional setup seen in v2.0. Hopefully this

weekend I will work on designing the new circuit board and replace the blocking diode and the zener voltage regulator with this chip. I will also be upping the storage capacity of the system by using two supercapacitors in parallel. With the extra storage capacity I can brighten the led with the same run time by switching out the 200Ohm current limiting resistor on the led to a 30Ohm resistor. This brings the forward current on the led from 4ma to 13ma and more then doubles the light output. You can check out the specifics on this chip and download the datasheet at: <http://www.zmdi.com/zspm4523> background music provided by MitiS under creative commons free use license. Check out his work at his soundcloud page: <http://soundcloud.com/mitis>

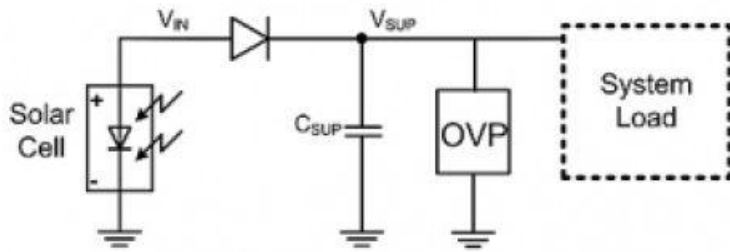

Figure 1: Schematic for charging a supercapacitor using a diode.

### A simple diode charger

The simplest way to charge a supercapacitor from a solar cell is through a diode. The supercapacitor can charge up to the open-circuit voltage of the solar cell under the prevailing light conditions, taking into account losses due to

the diode. **Figure 1** shows how a supercapacitor can be charged with the help of a diode. An auxiliary over-voltage

protection circuit is required in most systems to protect the supercapacitor and the ensuing load electronics.

Figure 1: Schematic for charging a supercapacitor using a diode.